



SSC8L34PN6

N-Channel Enhanced MOSFET

➤ Features

| VDS | VGS | RDSON Typ. | ID |
|-----|------|------------|------|
| 30V | ±20V | 1.85mΩ@10V | 100A |
| | | 3.2mΩ@4V5 | |

➤ Description

This device is N-Channel enhancement MOSFET. Uses SGT technology and design to provide excellent RDSON with low gate charge. This device is suitable for use in DC-DC conversion, power switch and charging circuit.

100% UIS + ΔVds + Rg Tested!

➤ Applications

- Load Switch
- Portable Devices
- DCDC conversion
- Power supplies
- Motor Drive Control
- Synchronous rectification

➤ Ordering Information

| Device | Package | Shipping |
|------------|------------|-----------|
| SSC8L34PN6 | PDFN5X6-8L | 5000/Reel |

➤ Pin configuration

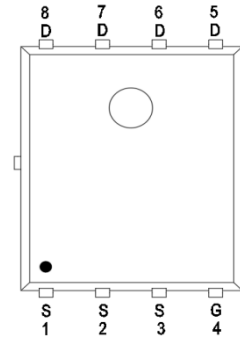

Top View

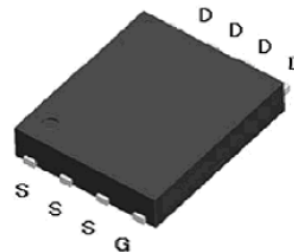

PDFN5X6-8L



Marking

(XX: product year / YY: product week)



➤ **Absolute Maximum Ratings**($T_A=25^{\circ}\text{C}$ unless otherwise noted)

| Symbol | Parameter | Ratings | Unit | |
|-----------|---|---------------------------|--------------------|---|
| V_{DSS} | Drain-to-Source Voltage | 30 | V | |
| V_{GSS} | Gate-to-Source Voltage | ± 20 | V | |
| I_D | Continuous Drain Current ^d | $T_C=25^{\circ}\text{C}$ | 100 | A |
| | | $T_C=100^{\circ}\text{C}$ | 65 | |
| I_{DSM} | Continuous Drain Current ^a | $T_A=25^{\circ}\text{C}$ | 38 | A |
| | | $T_A=70^{\circ}\text{C}$ | 26 | |
| I_{DM} | Pulsed Drain Current ^b | 400 | A | |
| P_D | Power Dissipation ^c | $T_C=25^{\circ}\text{C}$ | 56 | W |
| | | $T_C=100^{\circ}\text{C}$ | 22 | |
| P_{DSM} | Power Dissipation ^a | $T_A=25^{\circ}\text{C}$ | 6.2 | W |
| | | $T_A=70^{\circ}\text{C}$ | 4 | |
| I_{AS} | Avalanche Current ^b L=0.5mH Single Pulse | 30 | A | |
| E_{AS} | Avalanche Energy ^b L=0.5mH Single Pulse | 225 | mJ | |
| T_J | Operation junction temperature | -55~150 | $^{\circ}\text{C}$ | |
| T_{STG} | Storage temperature range | -55~150 | | |

➤ **Thermal Resistance Ratings**($T_A=25^{\circ}\text{C}$ unless otherwise noted)

| Symbol | Parameter | Ratings | Unit |
|-----------------|---|---------|-----------------------------|
| $R_{\theta JA}$ | Junction-to-Ambient Thermal Resistance ^a | 20 | $^{\circ}\text{C}/\text{W}$ |
| $R_{\theta JC}$ | Junction-to-Case Thermal Resistance | 2.2 | |

Note:

- The value of $R_{\theta JA}$ is measured with the device mounted on 1 in² FR-4 board with 2oz.copper, in a still air environment with $T_A=25^{\circ}\text{C}$.The value in any given application depends on the user is specific board design. The power dissipation is based on the $t \leq 10\text{s}$ thermal resistance rating.
- Repetitive rating, pulse width limited by junction temperature.
- The power dissipation P_D is based on $T_{J(\text{MAX})}=150^{\circ}\text{C}$, using junction-to-case thermal resistance, and is more useful in setting the upper dissipation limit for cases where additional heat sinking is used.
- The maximum current rating is package limited.



➤ **Electronics Characteristics**($T_A=25^{\circ}\text{C}$ unless otherwise noted)

| Symbol | Parameter | Test Conditions | Min | Typ. | Max | Unit |
|---------------|---------------------------------|--|-----|------|-----------|------------|
| $V_{(BR)DSS}$ | Drain-Source Breakdown Voltage | $V_{GS}=0V, I_D=250\mu A$ | 30 | | | V |
| $V_{GS(th)}$ | Gate Threshold Voltage | $V_{DS}=V_{GS}, I_D=250\mu A$ | 1.0 | 1.7 | 2.2 | V |
| $R_{DS(on)}$ | Drain-Source On-Resistance | $V_{GS}=10V, I_D=30A$ | | 1.85 | 2.6 | m Ω |
| | | $V_{GS}=4.5V, I_D=20A$ | | 3.2 | 4 | |
| I_{DSS} | Zero Gate Voltage Drain Current | $V_{DS}=30V, V_{GS}=0V$ | | | 1 | μA |
| I_{GSS} | Gate-Source leak current | $V_{GS}=\pm 20V, V_{DS}=0V$ | | | ± 100 | nA |
| G_{FS} | Transconductance | $V_{DS}=5V, I_D=20A$ | | 90 | | S |
| V_{SD} | Forward Voltage | $V_{GS}=0V, I_S=20A$ | | 0.8 | 1.3 | V |
| R_g | Gate Resistance | $V_{DS}=0V, f=1MHz$ | | 2.5 | | Ω |
| C_{iss} | Input Capacitance | $V_{DS}=15V, V_{GS}=0V, f=1MHz$ | | 2570 | | pF |
| C_{oss} | Output Capacitance | | | 1450 | | |
| C_{rss} | Reverse Capacitance | | | 115 | | |
| $T_{D(ON)}$ | Turn-on delay time | $V_{GS}=10V, R_L=1\Omega$ $V_{DS}=20V, R_G=3\Omega$ | | 10 | | ns |
| T_r | Rise time | | | 63 | | |
| $T_{D(OFF)}$ | Turn-off delay time | | | 45 | | |
| T_f | Fall time | | | 28 | | |
| Q_G | Total Gate Charge | $V_{GS}=10V, V_{DS}=15V$ $I_D=20A$ | | 39 | | nC |
| Q_{GS} | Gate Source Charge | | | 11 | | |
| Q_{GD} | Gate Drain Charge | | | 3.4 | | |
| T_{rr} | Diode Recovery Time | $I_F=20A, di/dt=100A/\mu s$ | | 42 | | ns |
| Q_{rr} | Diode Recovery Charge | $I_F=20A, di/dt=100A/\mu s$ | | 25 | | nC |



➤ **Typical Characteristics** ($T_A=25^\circ\text{C}$ unless otherwise noted)

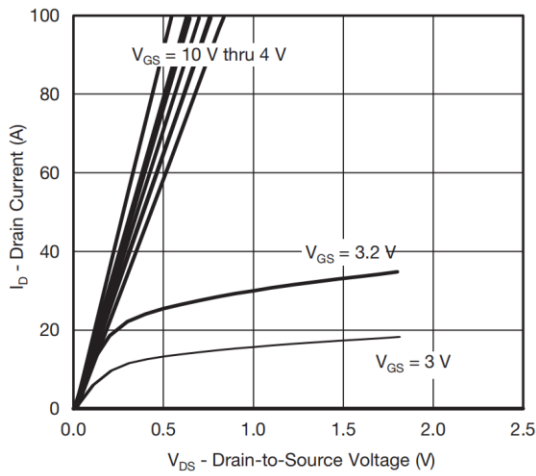

Output Characteristics

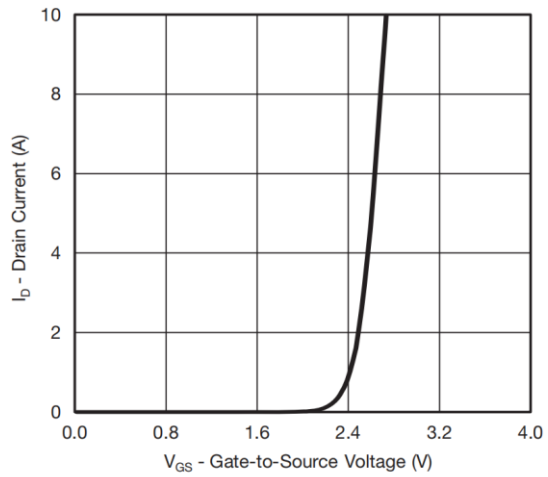

Transfer Characteristics

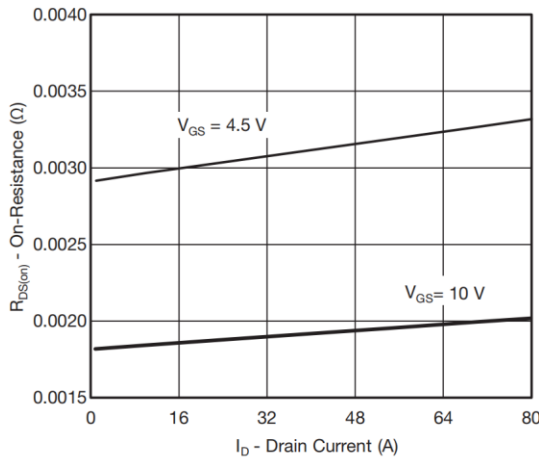

On-Resistance vs. Drain Current

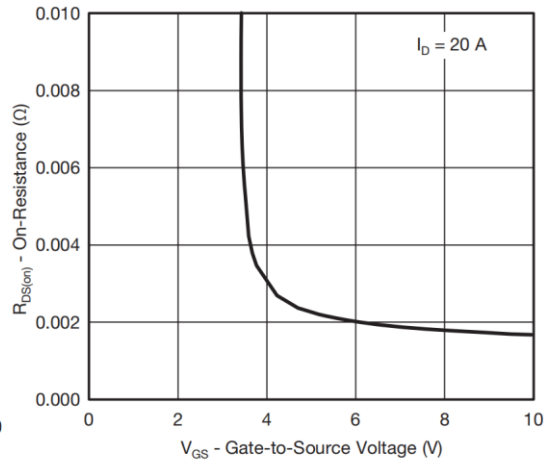

On-Resistance vs. Gate-to-Source Voltage

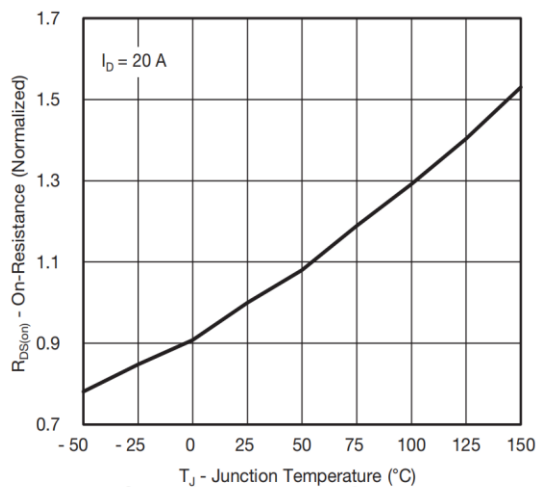

On-Resistance vs. Junction Temperature

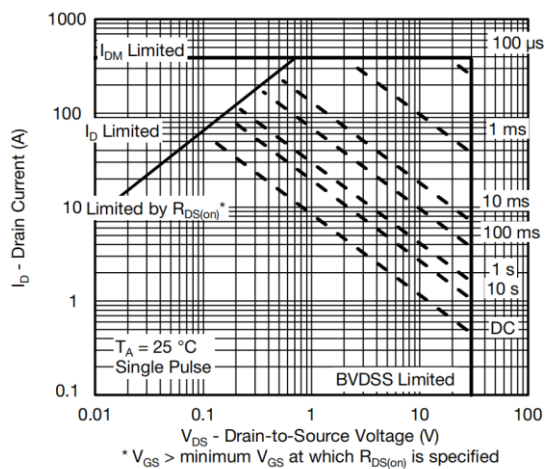

Safe Operating Area

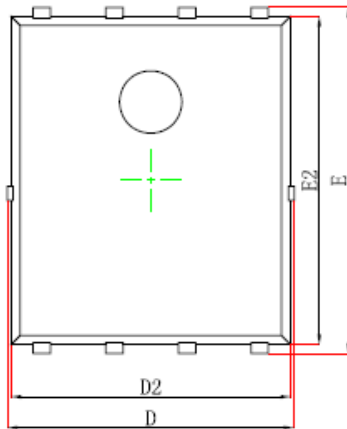
➤ Package Information

Top View
[顶视图]

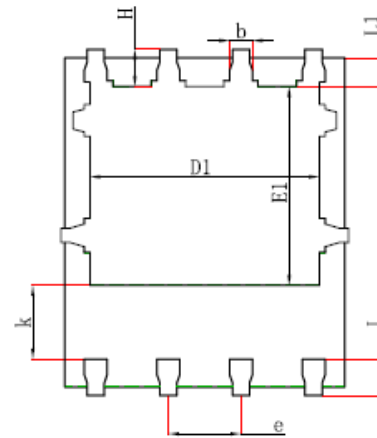

Bottom View
[背视图]

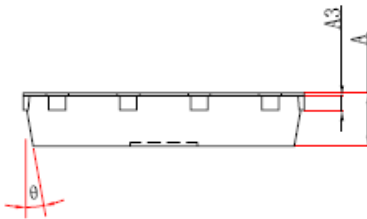

Side View
[侧视图]

Package: PDNF5X6-8L

| Symbol | Dimensions In Millimeters | | Dimensions In Inches | |
|--------|---------------------------|-------|----------------------|-------|
| | Min. | Max. | Min. | Max. |
| A | 0.900 | 1.000 | 0.035 | 0.039 |
| A3 | 0.254REF | | 0.010REF | |
| D | 4.944 | 5.096 | 0.195 | 0.201 |
| E | 5.974 | 6.126 | 0.235 | 0.241 |
| D1 | 3.910 | 4.110 | 0.154 | 0.162 |
| E1 | 3.375 | 3.575 | 0.133 | 0.141 |
| D2 | 4.824 | 4.976 | 0.190 | 0.196 |
| E2 | 5.674 | 5.826 | 0.223 | 0.229 |
| k | 1.190 | 1.390 | 0.047 | 0.055 |
| b | 0.350 | 0.450 | 0.014 | 0.018 |
| e | 1.270TYP | | 0.050TYP | |
| L | 0.559 | 0.711 | 0.022 | 0.028 |
| L1 | 0.424 | 0.576 | 0.017 | 0.023 |
| H | 0.574 | 0.726 | 0.023 | 0.029 |
| θ | 10° | 12° | 10° | 12° |



➤ Tape and Reel

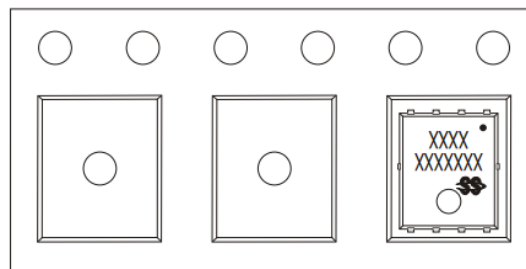
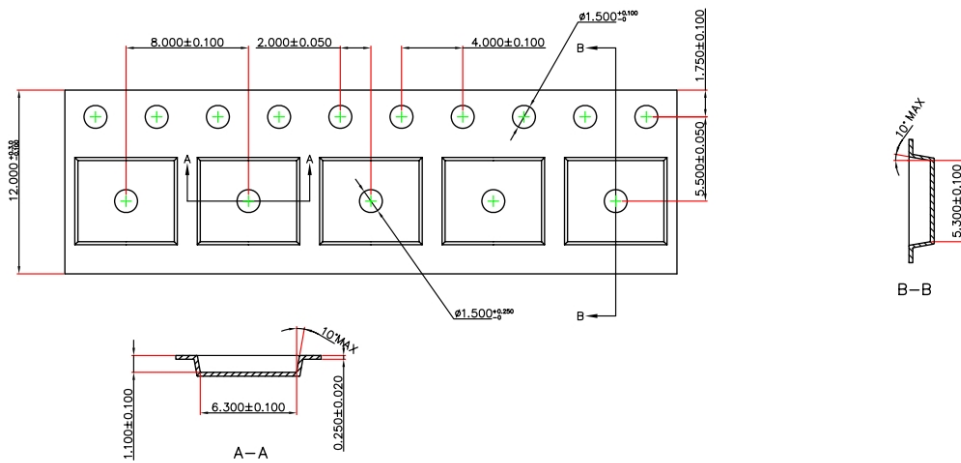
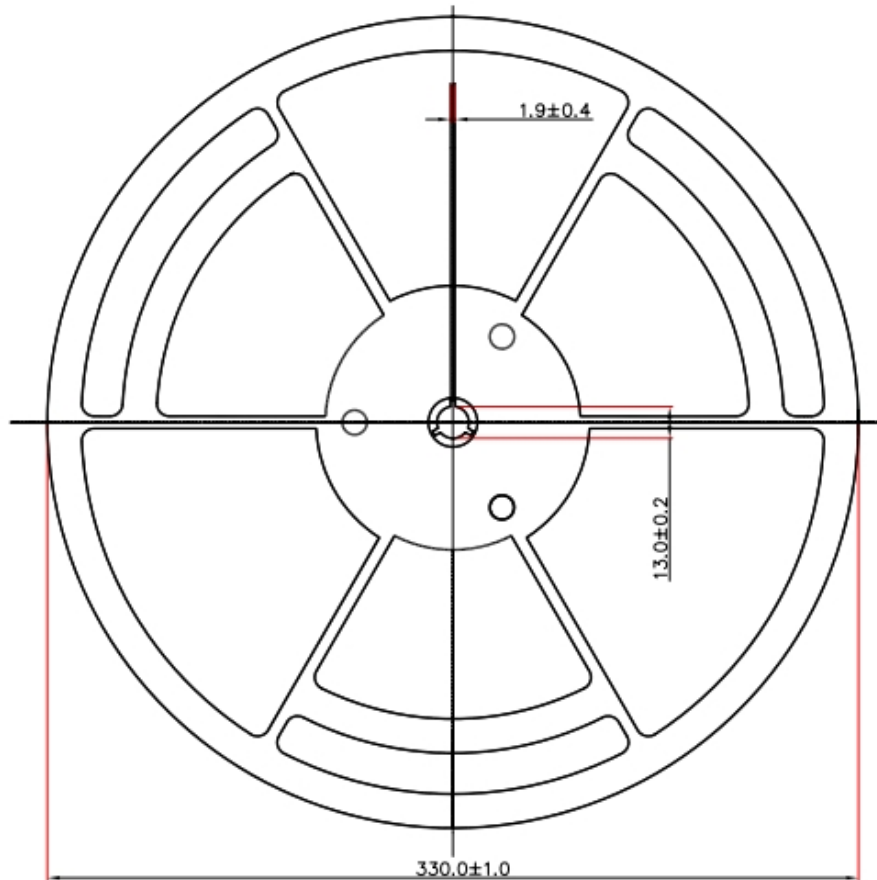



DISCLAIMER

AFSEMI RESERVES THE RIGHT TO MAKE CHANGES WITHOUT FURTHER NOTICE TO ANY PRODUCTS HEREIN TO IMPROVE RELIABILITY, FUNCTION OR DESIGN. AFSEMI DOES NOT ASSUME ANY LIABILITY ARISING OUT OF THE APPLICATION OR USE OF ANY PRODUCT OR CIRCUIT DESCRIBED HEREIN; NEITHER DOES IT CONVEY ANY LICIENCE UNDER ITS PATENT RIGHTS, NOR THE RIGHTS OF OTHERS.

THE GRAPHS PROVIDED IN THIS DOCUMENT ARE STATISTICAL SUMMARIES BASED ON A LIMITED NUMBER OF SAMPLES AND ARE PROVIDED FOR INFORMATIONAL PURPOSE ONLY. THE PERFORMANCE CHARACTERISTICS LISTED IN THEM ARE NOT TESTED OR GUARANTEED. IN SOME GRAPHS, THE DATA PRESENTED MAY BE OUTSIDE THE SPECIFIED OPERATING RANGE (E.G. OUTSIDE SPECIFIED POWER SUPPLY RANGE) AND THEREFORE OUTSIDE THE WARRANTED RANGE.

OUR PRODUCT SPECIFICATIONS ARE ONLY VALID IF OBTAINED THROUGH THE COMPANY'S OFFICIAL WEBSITE, CRM SYSTEM, OR OUR SALES PERSONNEL CHANNELS. IF CHANGES OR SPECIAL VERSIONS ARE INVOLVED, THEY MUST BE STAMPED WITH A QUALITY SEAL AND MARKED WITH A SPECIAL VERSION NUMBER TO BE VALID.